

Technical Specifications

Max. Flow Rate	90 gpm (340 L/min)
Fluid Displacement Per Cycle*	0.4 gal. (1,5 L)
Max. Pump Speed	225 cpm
Max. Fluid Working Pressure	120 psi (8 bar)
Air Pressure Operating Range*	20-120 psi (1,4 - 8 bar)
Max. Particulate Size (Dia.)	3.8" (96,5 mm)
Max. Suction Lift	Wet 30 ft. (9,1 m) / Dry 5 ft. (1,5 m)
Max. Temperature	180°F (82.2°C)
Elastomers/Diaphragms	EPDM / Overmolded PTFE
Center Block	316SS
Fluid Section	316SS
Port Configuration	Horizontal Wye
Intake / Discharge Connection	4" Tri-Clamp®
Air Inlet / Exhaust Size	1/2" npt(f) / 3/4" npt(f)
Noise Level at 70 psi (4,8 bar)	85 dBa
Max. Viscosity**	15,000 cps (mPas)
Shipping Weight	168 lbs.(76,2 kg)

Technical Notes:

* Flow rate and displacement per cycle may vary based on suction condition, discharge head, air pressure, and fluid type.

** Viscosity range may vary due to factors such as suction condition and media composition.

All fluid contact materials are FDA-compliant and meet the United States Code of Federal Regulations (CFR) Title 21 for repeated use in food-processing machinery. The pump user must verify that the construction materials meet their specific application requirements.

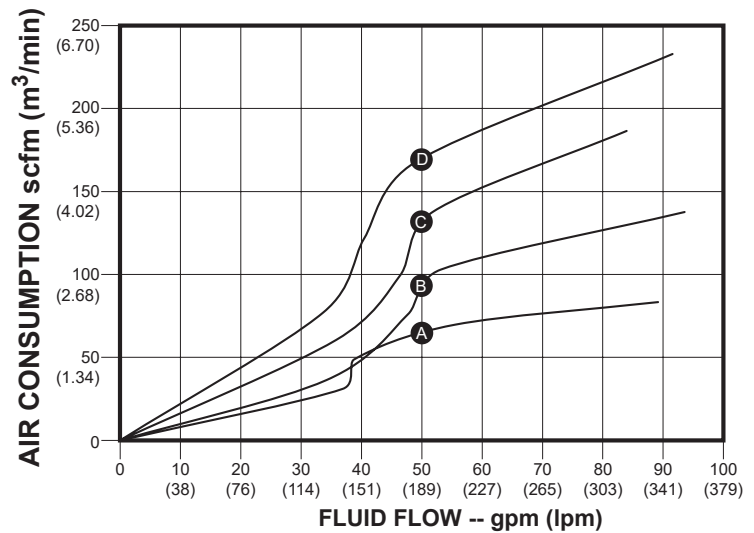
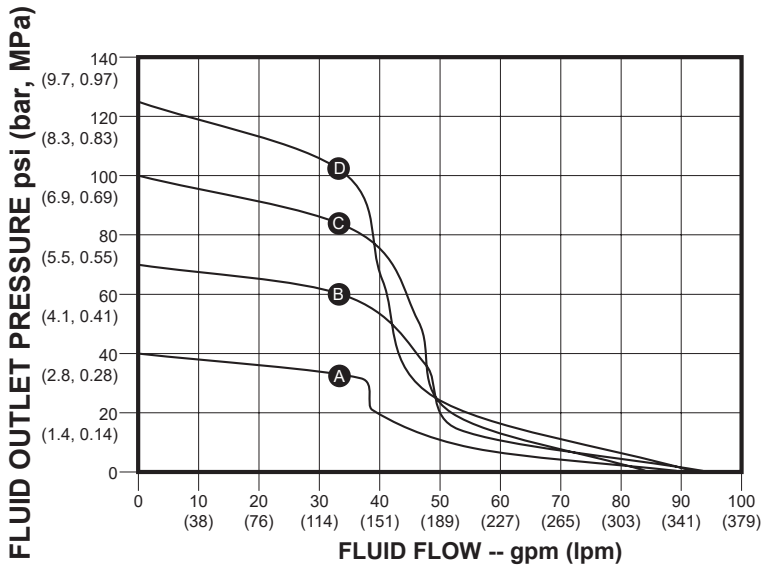
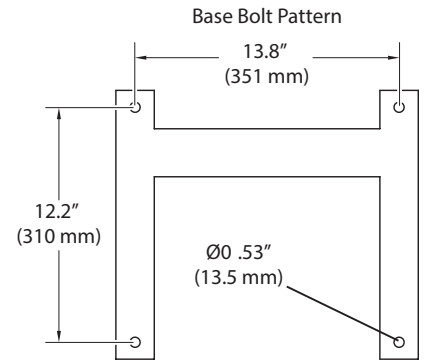
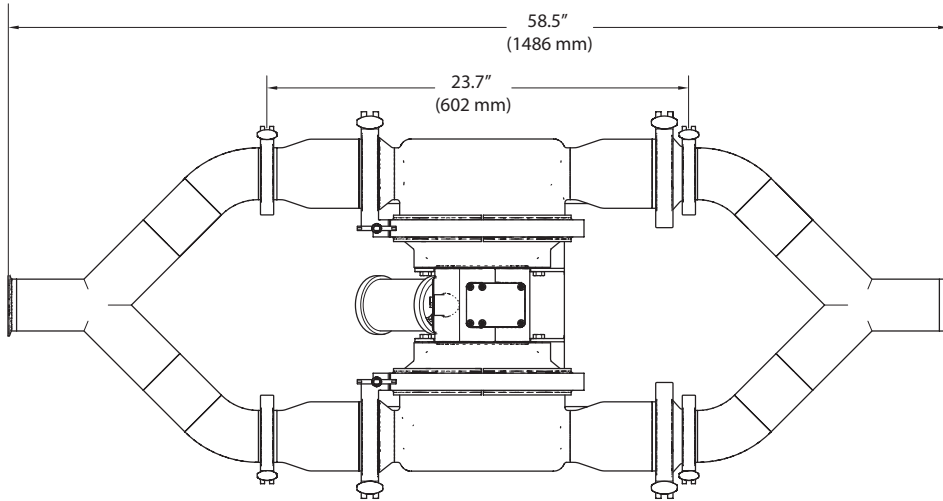

AIR PRESSURE

- D** 120 psi air (8.4 bar, 0.84 MPa)
- C** 100 psi air (7 bar, 0.7 MPa)
- B** 70 psi air (4.8 bar, 0.48 MPa)
- A** 40 psi air (2.8 bar, 0.28 MPa)

Note: Pump tested in water with inlet submerged.