

## Technical Specifications

<b>Max. Flow Rate</b> .....	130 gpm (492 L/min)
<b>Fluid Displacement Per Cycle*</b> .....	0.7 gal. (2,65 L)
<b>Max. Pump Speed</b> .....	180 cpm
<b>Max. Fluid Working Pressure</b> .....	120 psi (8 bar)
<b>Air Pressure Operating Range*</b> .....	20-120 psi (1,4 - 8 bar)
<b>Max. Particulate Size (Dia.)</b> .....	2.46" (62,5 mm)
<b>Max. Suction Lift</b> .....	Wet 30 ft. (9,1 m) / Dry 6 ft. (1,8 m)
<b>Max. Temperature</b> .....	180°F (82.2°C)
<b>Elastomers/Diaphragms</b> .....	EPDM / Overmolded PTFE
<b>Center Block</b> .....	316SS
<b>Fluid Section</b> .....	316SS
<b>Port Configuration</b> .....	Center Horizontal
<b>Intake / Discharge Connection</b> .....	3" Tri-Clamp®
<b>Air Inlet / Exhaust Size</b> .....	1/2" npt(f) / 3/4" npt(f)
<b>Noise Level at 70 psi (4,8 bar)</b> .....	85 dBa
<b>Max. Viscosity**</b> .....	15,000 cps (mPas)
<b>Shipping Weight</b> .....	118 lbs.(53,5 kg)

### Technical Notes:

\* Flow rate and displacement per cycle may vary based on suction condition, discharge head, air pressure, and fluid type.

\*\* Viscosity range may vary due to factors such as suction condition and media composition.

All fluid contact materials are FDA-compliant and meet the United States Code of Federal Regulations (CFR) Title 21 for repeated use in food-processing machinery. The pump user must verify that the construction materials meet their specific application requirements.

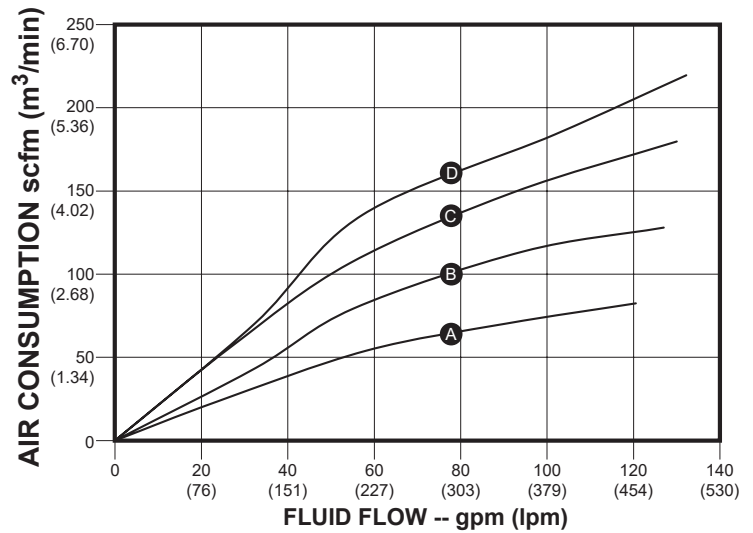
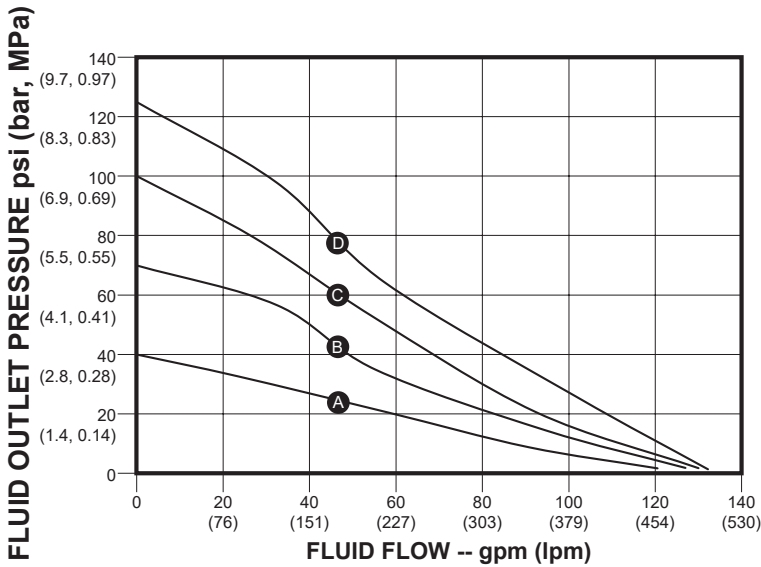
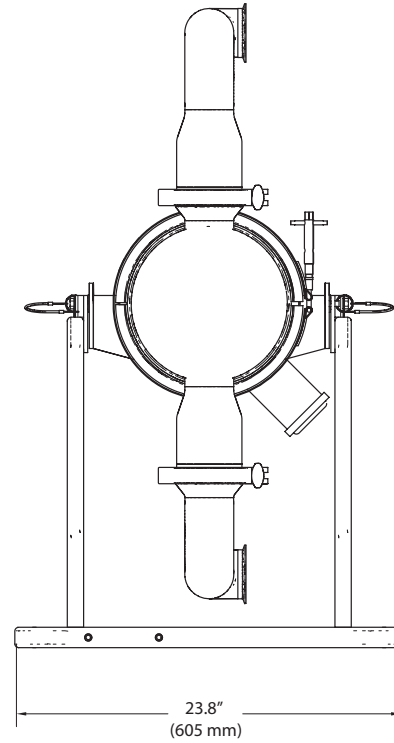
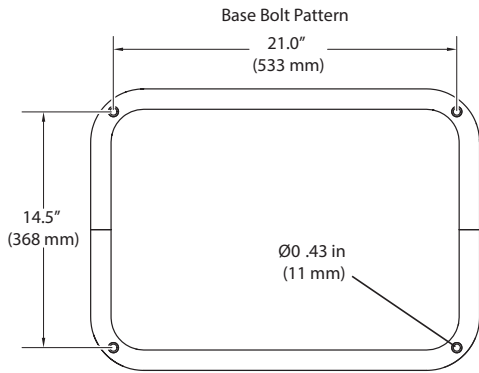

**AIR PRESSURE**

- D 120 psi air (8.4 bar, 0.84 MPa)
- C 100 psi air (7 bar, 0.7 MPa)
- B 70 psi air (4.8 bar, 0.48 MPa)
- A 40 psi air (2.8 bar, 0.28 MPa)

Note: Pump tested in water with inlet submerged.