



Operation Instructions & Parts Manual

Industrial Nozzle Models:

Prolypropylene - 9070, 9070e, 9071 &
PVDF - 9090, 9090e, 9091 & 9091e

OIPM-IND-202603



Industrial Nozzle Models:

Polypropylene – 9070, 9070e, 9071 & 9071e PVDF – 9090, 9090e, 9091 & 9091e

Hand Nozzle Specifications

Nozzle Pressure Drop



Polypropylene –
9070, 9070e, 9071 & 9071e
Max Temp: 212° F (100° C)



PVDF –
9090, 9090e, 9091 & 9091e
Max Temp: 302° F (150° C)

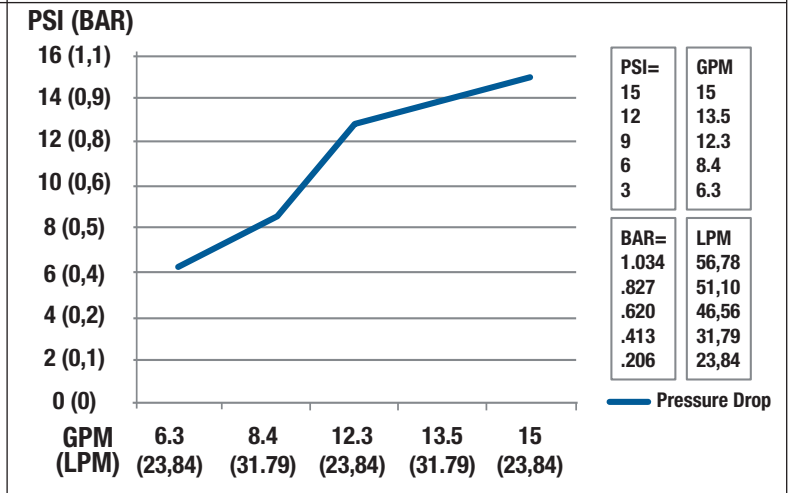

Spare Parts List

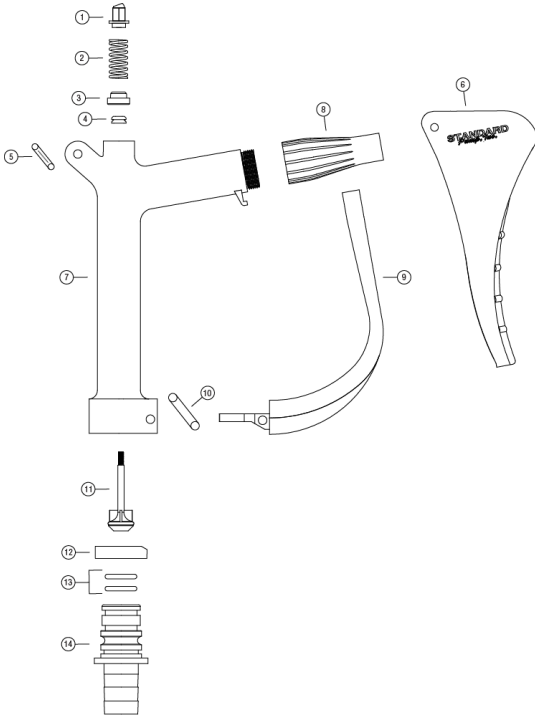

Reference Number	Description	Part Number for Models 9070, 9070e, 9071, 9071e	Part Number for Models 9090, 9090e, 9091, 9091e	Qty
1	Valve Stem Nut	9060-08	9080-08	1
2	Valve Spring, SS316	9060-11	9060-11	1
3	Valve Stop	9060-06	9080-06	1
4	Valve Stop Seal			1
	Viton®	1000	1000	
	PTFE	9060-23	9060-23	
5	Trigger Retaining Pin, SS	9060-16	9060-16	1
6	Trigger, PP	9060-10	9060-10	1
7	Nozzle Body	9060-01	9080-01	1
8	Nozzle Spout	9060-02	9080-02	1
9	Trigger Guard, PP	9060-12	9060-12	1
10	Trigger Guard Retaining Pin, SS	9060-17	9060-17	1
11	Valve Stem			1
	Viton®	9060-07V	9080-07V	
	EPDM	9060-07E	9080-07E	
12	Hose Barb Adapter	9060-05	9080-05	1
13	Hose Barb O-Ring			1
	Viton®	9060-13	9060-13	
	EPDM	9060-22	9060-22	
14	Hose Barb			1
	3/4" (19 mm)	9060-04	9080-04	
	1" (25 mm)	9060-03	9080-03	

Industrial Nozzle Models:

Polypropylene – 9070, 9070e, 9071 & 9071e PVDF – 9090, 9090e, 9091 & 9091e

Disassembly Procedure

1. Remove the nozzle spout (Figure 1).

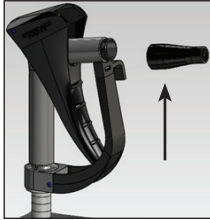

Figure 1

2. Using an arbor press and 6 mm punch insert, press out the trigger retaining pin and trigger guard retaining pin (Figure 2 & 3).

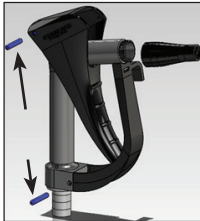

Figure 2

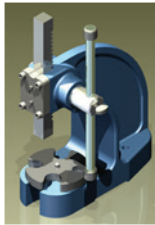

Figure 3

3. Remove the trigger guard and remove the trigger (Figure 4 & 5).

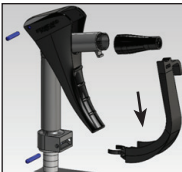

Figure 4

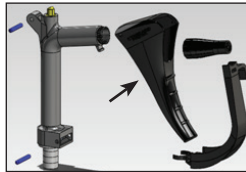

Figure 5

4. Remove the hose barb (Figure 6).

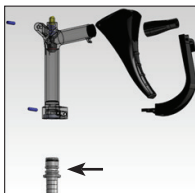

Figure 6

5. Remove the hose barb hose ring (Figure 7).

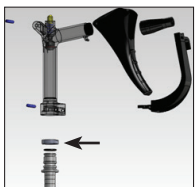

Figure 7

6. Remove the nozzle retaining ring (Figure 8).

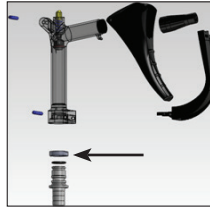

Figure 8

7. Remove the dome nut and valve assembly spring (Figure 9).



Note: During reassembly insure the sloped face of the dome nut is pointed towards the rear of the nozzle (Figure 10).

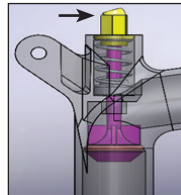

Figure 10

8. For the disassembly of the valve assembly use a 10 mm wrench for the dome nut and a long 6 mm allen wrench for the valve stem (Figure 11).

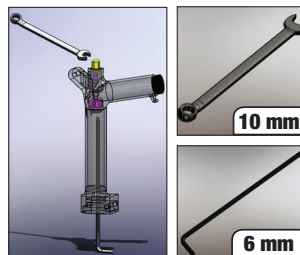

Figure 11

9. Remove the valve stem (Figure 12). Remove the valve assembly o-ring (Figure 13).

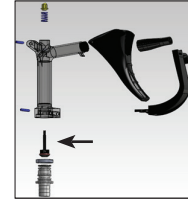

Figure 12

Note: It is recommended to use rubber o-ring bonder during reassembly for high pressure applications.

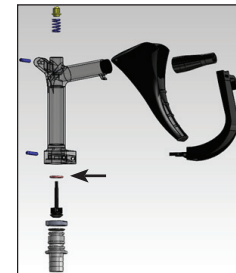

Figure 13



10. Remove the valve stop and valve stop o-rings (Figure 14).

Note: It is recommended to lubricate all o-rings during reassembly (Figure 14)

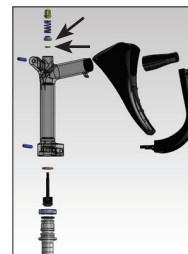

Figure 14

WARRANTY

Three year limited warranty

Standard Pump, Inc. warrants, subject to the conditions below, through either Standard Pump, Inc., its subsidiaries, or its authorized distributors, to repair or replace free of charge, including labor, any part of this equipment which fails within **three years** of delivery of the product to the end user. Such failure must have occurred because of defect in material or workmanship and not as a result of operation of the equipment other than in accordance with the instructions given in this material. Specific exceptions include:

- Consumable items such as motor brushes, bearings, couplings and impellers. (Motor brushes typically have a life span of approximately 250 hours. This will vary with the manner in which the motor is used)

Conditions of exceptions include:

- Equipment must be returned by prepaid carriage to Standard Pump, Inc., its subsidiary or authorized distributor.
- All repairs, modifications must have been made by or with express written permission by Standard Pump, Inc., its subsidiary or authorized distributor.
- Equipment which have been abused, misused, or subject to malicious or accidental damage or electrical surge are excluded.

Warranties purporting to be on behalf of Standard Pump, Inc. made by any person, including representatives of Standard Pump, Inc, its subsidiaries, or its distributors, which do not fall within the terms of this warranty shall not be binding upon Standard Pump, Inc. unless expressly approved in writing by a Director or Manager of Standard Pump, Inc. Information for returning pumps Equipment which has been contaminated with, or exposed to, bodily fluids, toxic chemicals or any other substance hazardous to health must be decontaminated before it is returned to Standard Pump, Inc, or its distributor. A returned goods authorization number (RGA #) issued by Standard Pump, Inc., its subsidiary or authorized distributor, must be included with the returned equipment. The RGA # is required if the equipment has been used. If the equipment has been used, the fluids that have been in contact with the pump and the cleaning procedure must be specified along with a statement that the equipment has been decontaminated.

Unibloc Hygienic Technologies US, LLC

1650 Airport Rd, Ste 110 • Kennesaw, GA 30144 • USA

Tel 770-218-8900 • E-Mail sales@unibloctech.com