

**#54 Y-STRAINER**

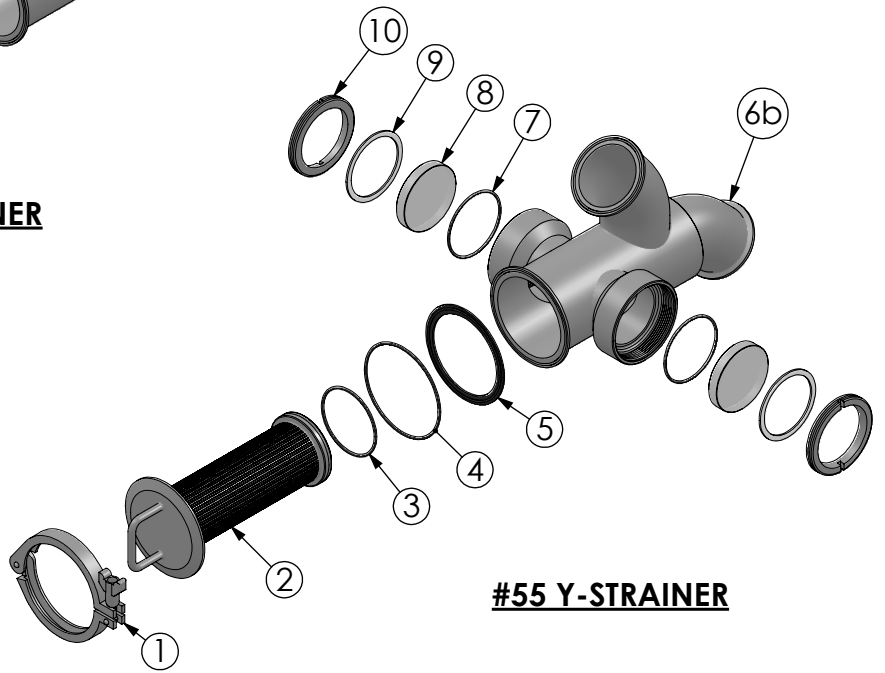

**#55 Y-STRAINER**

CONN. SIZE	ITEM	CLAMP	SCREEN INSERT	O-RING	O-RING	CLAMP GASKET	BODY	BODY	O-RING	GLASS	PTFE WASHER	RETAINER RING
		1	2	3	4	5	6A	6B	7	8	9	10
3/4"	P.N.	540085	540014	4281	N.A.	6302	540000	N.A.	N.A.	N.A.	N.A.	N.A.
	PCS.	1	1	1	-	1	1	-	-	-	-	-
1"	P.N.	540085	540014	4281	N.A.	6302	540001	N.A.	N.A.	N.A.	N.A.	N.A.
	PCS.	1	1	1	-	1	1	-	-	-	-	-
1.5"	P.N.	540086	540015	4282	N.A.	6303	540002	550002	4225	520025	520018	520011
	PCS.	1	1	1	-	1	1	1	2	2	2	2
2"	P.N.	540087	540016	4283	N.A.	6304	540003	550003	4274	520026	520019	520012
	PCS.	1	1	1	-	1	1	1	2	2	2	2
2" (1.0 FT <sup>2</sup> )	P.N.	540090	540019	4286	4210	4845	540003F	550003F	4275	520028	520021	520014
	PCS.	1	1	1	1	1	1	1	2	2	2	2
2.5"	P.N.	540088	540017	4284	N.A.	6305	540004	550004	4274	520026	520019	520012
	PCS.	1	1	1	-	1	1	1	2	2	2	2
3"	P.N.	540089	540018	4285	N.A.	6306	540005	550005	4806	520027	520020	520013
	PCS.	1	1	1	-	1	1	1	2	2	2	2
3" (1.0 FT <sup>2</sup> )	P.N.	540090	540019	4286	4210	4845	540005F	550005F	4275	520028	520021	520014
	PCS.	1	1	1	1	1	1	1	2	2	2	2
4" (1.0 FT <sup>2</sup> )	P.N.	540090	540019	4286	4210	4845	540006	550006	4275	520028	520021	520014
	PCS.	1	1	1	1	1	1	1	2	2	2	2
4" (2.25 FT <sup>2</sup> )	P.N.	540090	540020	4286	4210	4845	540007	550007	4275	520028	520021	520014
	PCS.	1	1	1	1	1	1	1	2	2	2	2
6" (3.5 FT <sup>2</sup> )	P.N.	540091	540021	4804	N.A.	6315	540008	550008	POA	520029	520022	520015
	PCS.	1	1	1	-	1	1	1	2	2	2	2

**NOTES:**

- SEAL MATERIALS ARE SPECIFIED AS FOLLOWS:  
 #-E (EPDM)      #-V (VITON)  
 #-S (SILICONE)    #-T (TEFLON ENCAPSULATED VITON)
- INSERT SCREEN SIZES ARE SPECIFIED AS FOLLOWS:  
 #-100M (100 mesh)    #-50M (50 mesh) and so on.....
- STRAINER MUST BE CLEANED OUT OF PLACE (COP)

THIS DRAWING AND ALL IDEAS INCORPORATED IN ITS DESIGN IS THE EXCLUSIVE PROPERTY OF UNIBLOC PUMP, LLC. ITS ACCEPTANCE CONSTITUTES AN AGREEMENT THAT IT SHALL BE TREATED AS A CONFIDENTIAL DOCUMENT USED FOR NO OTHER PURPOSE THAN TO AID IN ITS CONSTRUCTION, THAT IT IS TO BE RETURNED UPON REQUEST, AND THAT IT IS NOT TO BE DISCLOSED OR COPIED EXCEPT AS AUTHORIZED IN WRITING BY UNIBLOC PUMP, LLC.



DRAWN	BY	DATE
CHECKED	JC	01/18/16
APP'D		
SCALE		
ALL DIMENSIONS IN MM [IN]		

DWG. TITLE <b>#54 &amp; #55 Y-STRAINER COMPONENTS</b>		
SIZE <b>0.75"- 4"</b>	DWG. NO. <b>540998</b>	REV. NO. <b>8</b>
RELEASE DATE <b>JUNE 14, 2022</b>	SHEET 1 OF 2	