

SANITARY PRESSURE RELIEF VALVES

When it counts,
count on Unibloc®.

- 0.5" to 6" sizes
- SimpleSet™ fully adjustable pressure
- Easy CIP operation
- FlowTight™ positive lock construction
- Ideal for pharmaceutical/biotech, food/
beverage and chemical applications



PROVEN UNDER PRESSURE

Hygenitec sanitary Pressure Relief Valves are engineered for greater flexibility and protection from over-pressurization. Ideal for installation along the entire process line, these valves are fully adjustable from 10 to 105 psig without the need for special tools – providing greater control and consistent performance. 316 stainless steel material ensures hygienic operation. Optional Hastelloy-C or AL-6XN construction protects against highly corrosive environments.

Fully adjustable pressure settings from 10-105 psi for greater flexibility and ease-of-use

Additional Optional Features

- **200 psig springs** available on select sizes
- **Polish** up to 15 Ra (0.4 micron, μm) and/or electropolishing
- **Air to Air (A-A)** or **Air to Spring (A-S)** **air-override available** on 1.5" and 2.0" sizes
- **Material test report available**

Electropolished finish removes microscopic imperfections for an ultra-hygienic design



ENGINEERED FOR GREATER FLEXIBILITY

SIMPLESET™ ADJUSTABILITY

Hygenitec sanitary Pressure Relief Valves are fully adjustable, ideal for precise setting requirements and easier process changes. The SimpleSet™ design enables adjustments without removing the valve from the process line. A locking mechanism and stainless steel cap protect against accidental pressure changes and tampering.

EASY CIP OPERATION

An external stem lifter makes Clean-In-Place sanitation a breeze. Simply lift the plunger manually to allow thorough cleaning of the valve. Once cleaning is complete, the SimpleSet feature also returns the pressure to its predetermined setting.

LARGEST SELECTION, IN STOCK

Hygenitec sanitary Pressure Relief Valves are available in a wide range of sizes for consistent performance throughout a variety of processes. A large inventory is always on hand for fast shipping, keeping your operation running at peak performance.

Available sizes:

0.5", 0.75", 1", 1.5", 2", 2.5", 3", 4", 6"

PROVEN FLOWTIGHT™ DESIGN

A trapped O-ring, positively secured between the cap and stem, ensures a tight seal. USP Class VI elastomers come in standard FKM material with optional EPDM, Silicone or PTFE-encapsulated FKM. The valve body and spring chamber are connected by sanitary Tri-Clamp connection for easy disassembly without removal for service from the process line.



**Reliable
performance**
in sizes from
1/2 to 6 inches

Fully adjustable
even at 0.5"



Adjustment locking
mechanism and
cap protect against
accidental pressure
changes

SPECIFICATIONS

Pressure Relief Valve Dimensions

SIZE (A) in	B in (mm)	C in (mm)	Weight lb (kg)
0.5"	4.1(104)	1.2(30)	1.2(1)
0.75"	4.1(104)	1.2(30)	1.2(1)
1.0"	11.2(285)	2.8(70)	6.0(3)
1.5"	11.2(285)	2.8(70)	7.0(4)
2.0"	13.2(335)	3.5(89)	10.5(5)
2.5"	13.2(335)	3.5(89)	12.0(6)
3.0"	16.3(414)	6.3(159)	22.0(10)
4.0"	17.1(434)	6.3(159)	29.0(13)
6.0"	30.3(770)	5.4(138)	170.0(78)

Pressure Relief Valve Applications

STD Pressure Range Optional	10-105 psig
	up to 200 psig**
STD Maximum System Pressure	105 psig**
STD Inside Finish	32 Ra (0.8 micron, μm)
STD O-Ring Material	Viton

* 1cps (water at ambient temp • Technical changes without notice **

On select sizes - 0.5", 0.75" up to 125 psig; 1.0", 2.0" up to 200 psig

SIZES 0.5" - 0.75"

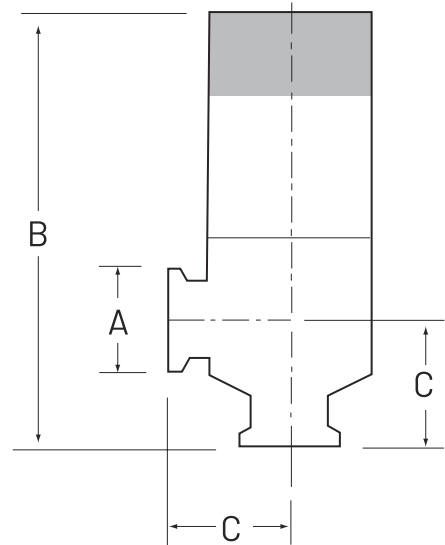

SIZES 1.0" - 6.0"

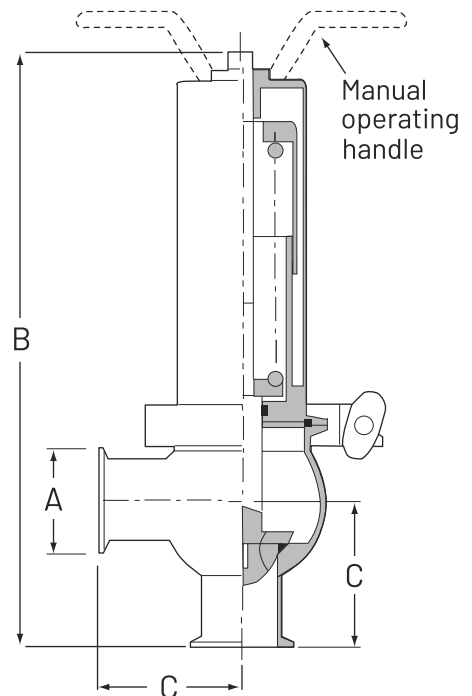

Unibloc Hygienic Technologies provides a broad portfolio of powerful solutions for companies around the world.